

Introduction

Cloudberry CM/CR Series with

High-availability Seamless Redundancy (HSR) technology

Øyvind Holmeide

April 25th 2018



HIGH-AVAILABILITY
SEAMLESS
REDUNDANCY



High-availability Seamless Redundancy (HSR)

- How can we achieve high-availability for critical networks?
- How can we make our data networks even more reliable?
- How can we guarantee zero data loss in case of failure?

Answer:

**High-availability Seamless Redundancy
(HSR) technology**



High-availability Seamless Redundancy (HSR)

■ What is HSR?

- HSR is a new network protocol for Ethernet that provides seamless failover against failure of a network component.
- HSR supports dual-port full duplex Ethernet communication
- When coupled with IEEE 1588 Precision Time Protocol (PTP), HSR allows also for high-accuracy time synchronization between network devices.
- HSR is suited for applications that require high availability and no switchover time, where the recovery time of commonly used protocols such as the Rapid Spanning Tree Protocol (RSTP) is too long.
- HSR provides hardware support (FPGA) to forward or discard frames within microseconds.



High-availability Seamless Redundancy (HSR)

- **What is HSR?**

- HSR network nodes, so called DAN H (double attached node for HSR), have at least two gigabit Ethernet ports, each attached to a neighboring HSR node, so that always two paths exist between two HSR nodes.

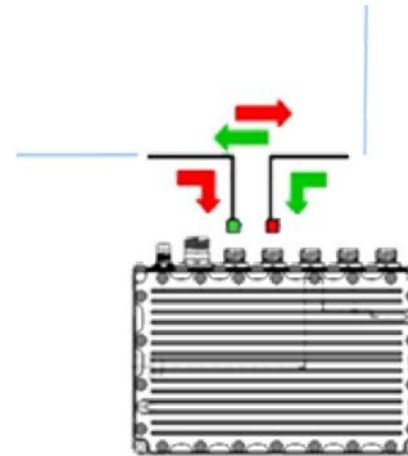

High-availability Seamless Redundancy (HSR)

▪ How does HSR work?

- Every HSR node is a switching node, i.e. it can forward a frame received on one port to at least one other port in cut-through mode.
- Therefore, as long as one path is operational, the destination application always receives one frame.
- HSR nodes check the redundancy continuously to detect lurking failures.



High-availability Seamless Redundancy (HSR)

▪ How does HSR work?

- The HSR node duplicates data packets and simultaneously transmits them in the ring
- The HSR header is used to encapsulate the Ethernet frame. This has the advantage that duplicates of all frames are recognized in all devices as soon as the HSR header has been received.
- There is no need to wait for the whole frame to be received before a duplicate can be recognized as such.
- This means that, similarly to cut-through switching, individual HSR connections and RedBoxes can begin forwarding the frame to the second ring-port as soon as its HSR header has been completely received and duplicate recognition carried out.



High-availability Seamless Redundancy (HSR)

■ What is HSR?

- Each HSR node takes from the network all frames that are addressed only to it and forwards them to the application.
- In Unicast operation the duplicate packet is removed at the destination
- Multicast and broadcast messages are forwarded by every node in the ring and are also passed to the application.
- In order to prevent multicast and broadcast frames from circulating forever, the node that initially placed the multicast or broadcast frame on the ring will remove it as soon as it has completed one cycle



High-availability Seamless Redundancy (HSR)

▪ Typical HSR Components

- RedBox (Interface box to connect non HSR equipment to a HSR network)
- Quadbox (Interface box to connect HSR rings)
- Virtual Quadbox (Same as Quadbox, but virtually created by connecting two RedBoxes with an Ethernet Link)
- The right solution for a wide variety of Aerospace and Defense applications, e.g. Unmanned vehicles, ground vehicles, aircraft, ships, etc.



High-availability Seamless Redundancy (HSR)

■ HSR Applications

- The right solution for a wide variety of Aerospace and Defense applications
 - Unmanned vehicles
 - Ground vehicles
 - Aircraft
 - Marine vessels
 - etc.



High-availability Seamless Redundancy (HSR)

- High-availability Seamless Redundancy (HSR)

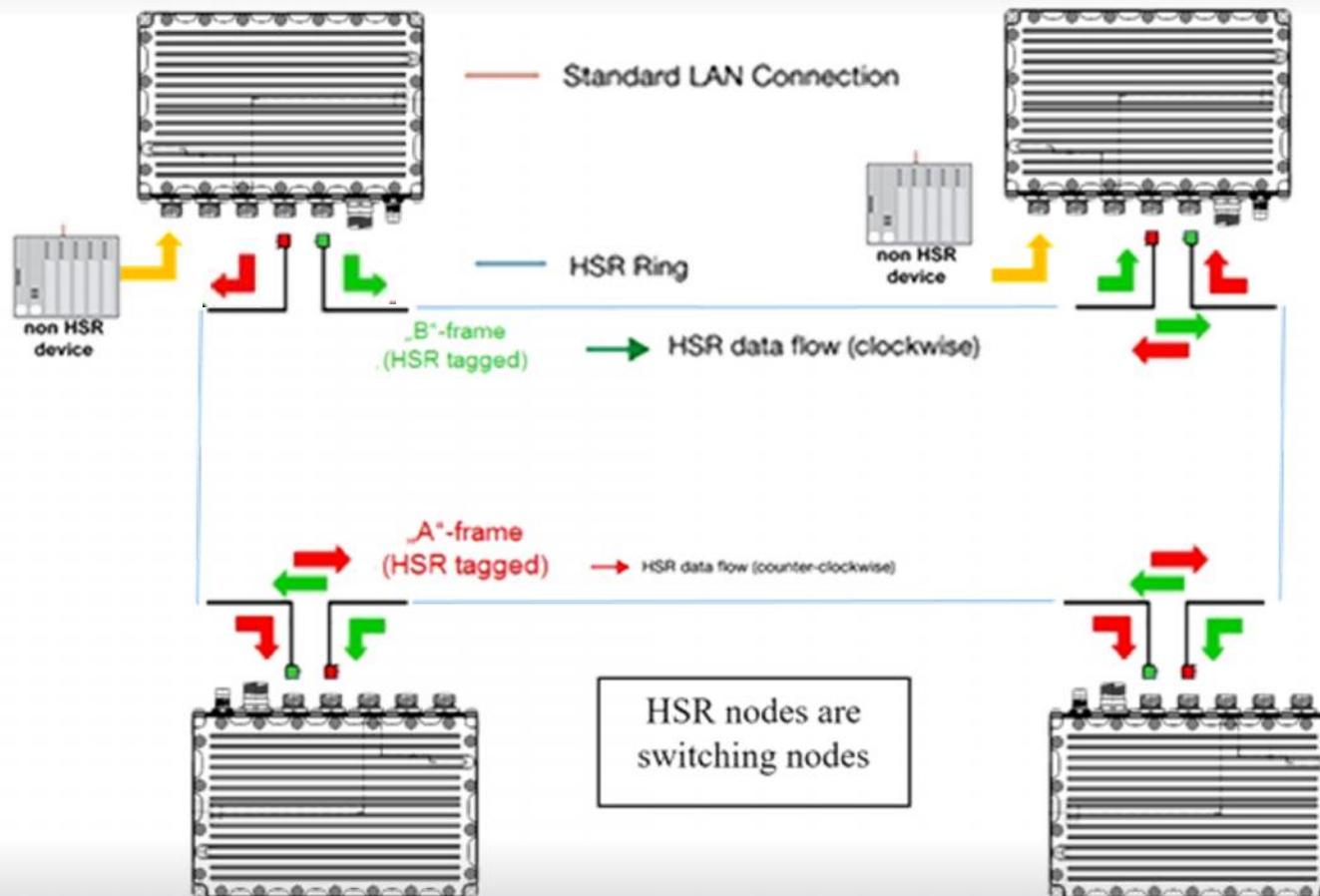

High-availability Seamless Redundancy (HSR)

■ Advantages of HSR

- Seamless data transmission with Zero time recovery (No packet loss)
- Maximum availability: No reconfiguration time, no data loss
- Reliable and cost effective
- Scalable and manageable
- No single point of failure
- Easy implementation: Allows for simple connection of devices without HSR capability (legacy devices)
- Fulfills the dependability and real-time requirements of the most demanding applications such as substation automation, military vehicles and motion control
- Suitable for use in stringent environmental conditions, e.g. high temperature, shock, vibration and EMC



High-availability Seamless Redundancy (HSR)

- **High-availability Seamless Redundancy (HSR) cont'd**
 - Cost effective redundancy with no single point of failure and zero recovery time
 - Fulfills the dependability and real-time requirements of the most demanding applications such as substation automation, military vehicles and motion control



CM-62xxFx-MIL

HSR support on CM-62xxFx-MIL:

- 2 x 1000BASE-T(x) ports, or
- 2 x 1000BASE-SX ports

Switch can also be configured with MSTP on on other 1G or 10G trunk ports.

